

# **PAMS Technical Documentation**

## **Loopset LPS-3**

### AMENDMENT RECORD SHEET

Amendment Number	Date	Inserted By	Comments
	<b>12/99</b>	OJuntune	

**CONTENTS**

	<b>Page No</b>
Loopset LPS-3 .....	4
Introduction .....	4
Basic Specification .....	5
List of Modules .....	5
Technical Specifications .....	6
Functional Description .....	6
Modes of Operation .....	6
Loopset detection .....	6
Loop Adapter .....	7
Magnetic Loop .....	7
Specification .....	7
Reception Specifications .....	7
Ratings .....	7
Automatic Gain Control (AGC) .....	7
Magnetic Field frequency response window .....	8
Functional Blocks .....	8
Distortion and noise .....	8
Microphone response window .....	9
External Signals and Connections .....	10
Exploded View of LPS-3 .....	12
Assembly parts of LPS-3 .....	12
Parts List of LPS-3 .....	13

## Loopset LPS-3

### Introduction

Hearing impaired people, who use hearing aids (HA), have problems in using cellular phones. They can't identify speech, partly due to poor S/N-ratio and partly because of interference. Most HA have poor protection for interferences. By using the Loopset the interference problems are minimized.

LPS-3 is designed for DCT3.5, DCT3.75 and DCT 4 series phones. 4-wire interface is implemented with 2.5mm diameter round plug/jack which is otherwise like "standard" stereo plug.

The Loopset has been developed for hearing aid users to allow them to use mobile phones. It is based on induction technology. These kind of induction devices are widely used with hearing aids, but never before implemented with cellular phones.

All hearing aids have support for induction loop, ie. they have a little telecoil inside. This coil can capture the signal supplied to the loop.

Standard hearing aids have two operation modes; M-mode for normal microphone use and T-mode for telecoil use

The T-mode is used in places where the inductive loop has been assembled, for example in public halls, churches and places of assembly. The reason for T-mode use is much better S/N-ratio.

The Loopset provides clear acoustic quality. The Loopset also dampens background noise to make it easier to converse in a noisy environment, in the car for instance.

The Loopset can be used with all the mobile phones, which supports normal headset and vibra alarm. Vibra is needed just for call indication. The earpiece of a headset is replaced by a wireloop. Loopset has also integrated microphone.

The earpiece of a headset is replaced by a wireloop. Loopset has also integrated microphone.

The function is very simple and the use is environmentally friendly. Loopset is passed around the neck. The system doesn't disturb anybody due to the silent service. When the phone is set to auto-answer mode, a user don't have to do anything but switch the hearing aid to T-mode.

Loopset is an economic and simple solution for hearing aid users. Most hearing aids are compatible to this kind of wireless handsfree.

## Basic Specification

Unit	Max. dimensions (mm) (W x H x D)	Notes
LPS-3	37mm x 40mm x 17mm	Weight 60g

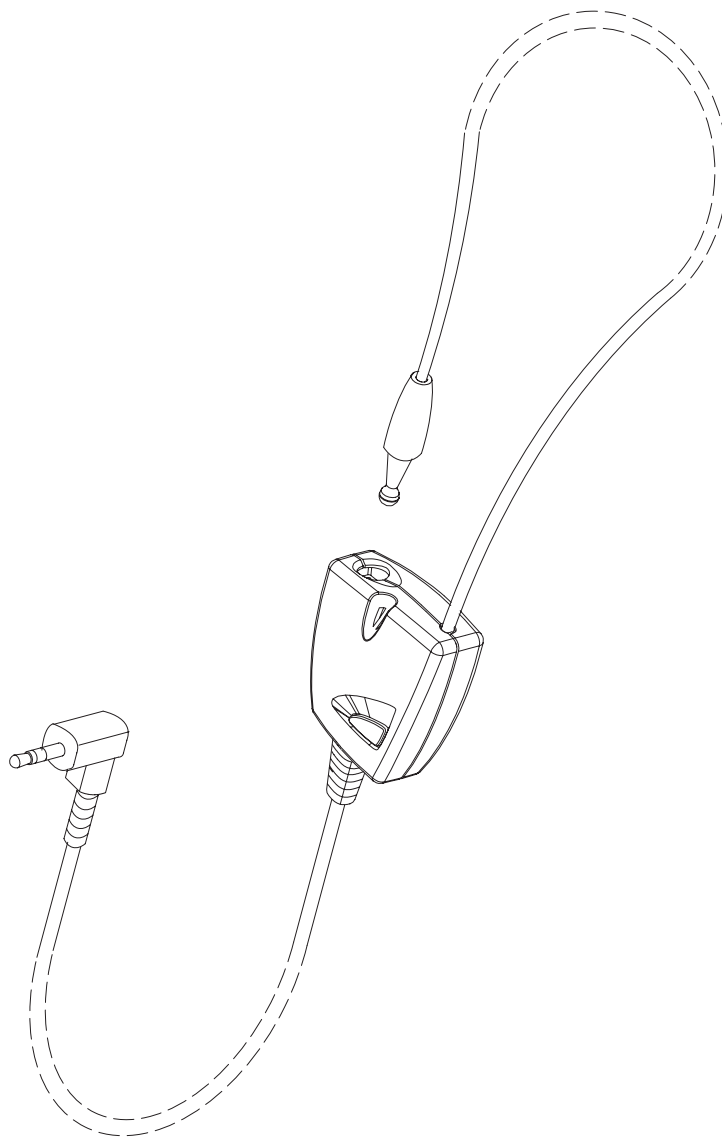

## List of Modules

Name of module	Type name	Material code	Note
LPS-3 Product	LPS-3	0630244	
LPS-3 Module	JL3	0201489	
Assembly parts	MLPS3	0262071	

Recommended batteries:

Type	Size / IEC-type	Min Vout	Max Vout	Rated capacity	Talk time. Duration of the battery continuing 3mA on load	Standby of dormancy. Battery continuing 20uA on load
Zinc Air Hearing Aid Battery	675 / PR44	1.15	1,40	540 mAh	180 hour.	840 hour or 35 day (1)
Silver Oxide Hearing Aid Battery	675 / SR44	1.25	1,55	150 mAh	50 hour.	7 500 hour or 310 day.
Alkaline Battery	675 / LR44	1.25	1,45	110 mAh	36 hour.	5 500 hour or 230 day.

(1) Note: The capacity of the zinc-air battery will fall 20% in a month. After the activation the zinc-air battery begins to self-discharge. The battery will be empty at the latest within 5 week.

## Technical Specifications

The Nokia LPS-3 Loopset is powered by three hearing aid batteries and comes pre-packaged with six zinc air batteries.

The "auto answer" feature of the phone allows the users to be "hands free" while using either the Nokia LPS-3 Loopset or headset accessories.

The interface between Loopset and phone is similier to a headset. Except the hight impedance input.

Name of function	Specification
Supply voltage	2,7 ... 4,5 V
Supply current	current peak 36 mA (nominal 3mA)

## Functional Description

### Modes of Operation

When the Loopset is identified the audio of the phone will be routed to the Loopset and the identification voltage is turned ON. Mic bias voltage 2.1V is turned ON only in call state.

When the phone is turned off also the Loopset is in off-mode.

### Loopset detection

In XMIC line there is a (47 + 2.2) kΩ pull-up in phone. A microphone is a low resistance pull down compared to that.

When there is no call going, AUXOUT is in high impedance state and XMIC is pulled up. When loopset is connected, XMIC is pulled down. XMIC is connected to HeadsetInt line (in MAD), so an interrupt is given due to both connection and disconnection.

During a call there is bias voltage (1.5 V) in AUXOUT. The state of HeadsetInt can't be sure. It is better to disable loopset interrupt during a call and poll from EAD line (AD converter in CCONT) to see if loopset is disconnected. Actually disconnection of a headset without remote control switch could be seen in HookInt, but headset with the switch could not.

**Loop Adapter**

Connection resistance must be under 3mΩ.

**Magnetic Loop**

The magnet field is based on the IEC 118-4 and BS 6083 part 4 standard.

**Specification**

**Reception Specifications**

Type of Function	Specification	Notes
Impedance	100k ohm +/- 5 % at 1 kHz	
Frequency response	See figure 1	
Magnetic field	100mA/m (RMS) ±3dB ref. 1kHz=0dB 400mA/m +12dB,125 ms RMS-peaks	The strength of the magnetic field measured next to the ear. (or measured in the horizontal plate and 170mm trip from the curve of the loop.)
Loop Current	700mA(RMS) ±3dB ref. 1kHz =>0dB 2,8A (RMS), 125 ms RMS peaks =>+12dB	
Automatic Gain Control	Response time <35 ms Resetting time 0,5-5dB/s	
Signal to Noise Ratio	855 dB	nominal level (122 mVrms)/1kHz

**Maximum Ratings**

Determined as defined by IEC 268 using signal limited to frequency range 300 ... 3400 Hz.

### Magnetic Field frequency response window

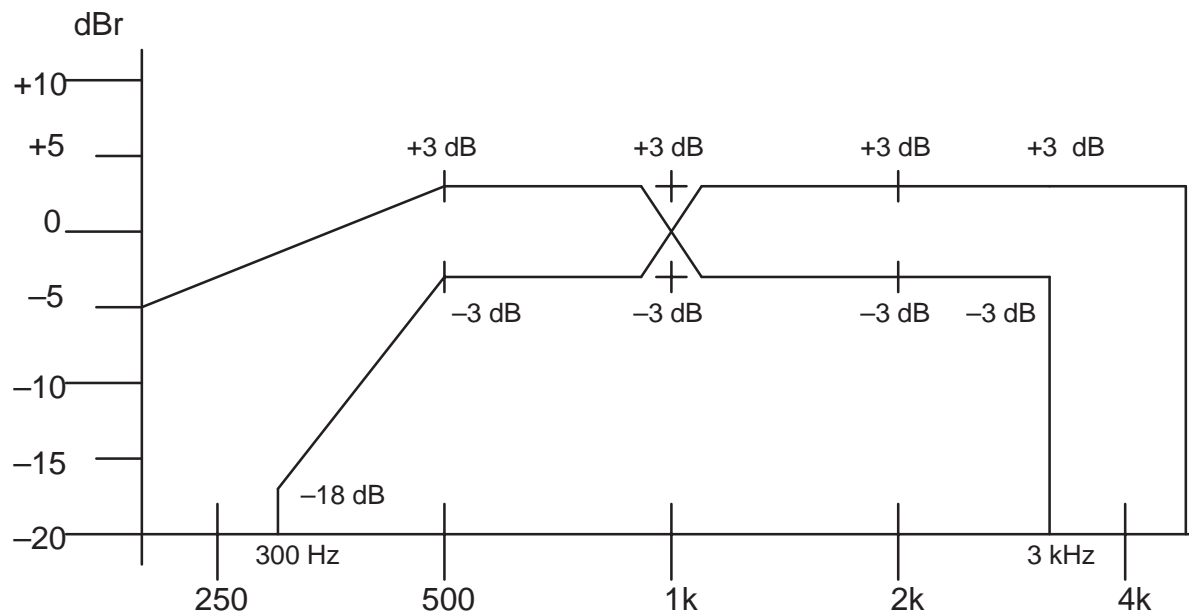

### Functional Blocks

Table 1. Transmission Specifications

Object	Specification	Notes
Output impedance	1600 ohm +/- 30% 1kHz	
Frequency response	See Figure 2	
Sensitivity	-48 dB +6/-3 dB at 1kHz	0dBv/PA
Sensitivity dBm0	-13 dBm0 +6/-3 dBm0 at 1kHz	0dBv/PA - 4,7 dBPA
Sensitivity	-59 dB +6/-3 dB at 1kHz	0dBv/PA.
Sensitivity dBm0	-24 dBm0 +6/-3 dBm0 at 1kHz	
Directivity mic (acoustic)	OMNI-directional	
Signal to Noise Ratio	55 dB	1Pa/1kHz

### Distortion and noise

Total distortion: Max 3 % 300...3400Hz with sound pressure 0 dBPa at the microphone.



**Microphone response window**

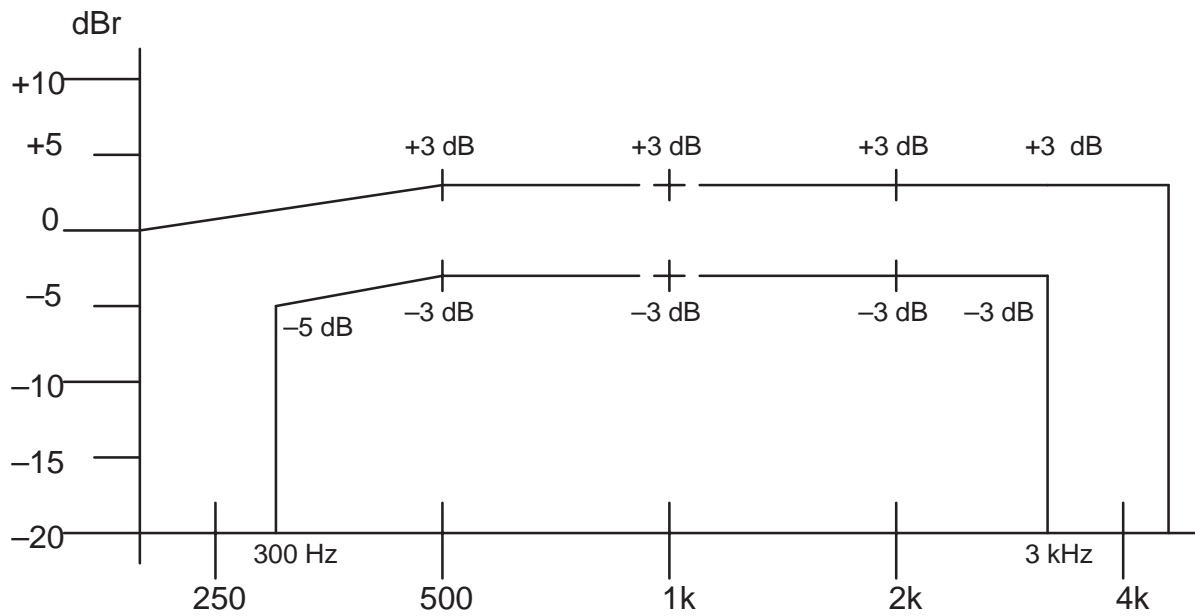

## External Signals and Connections

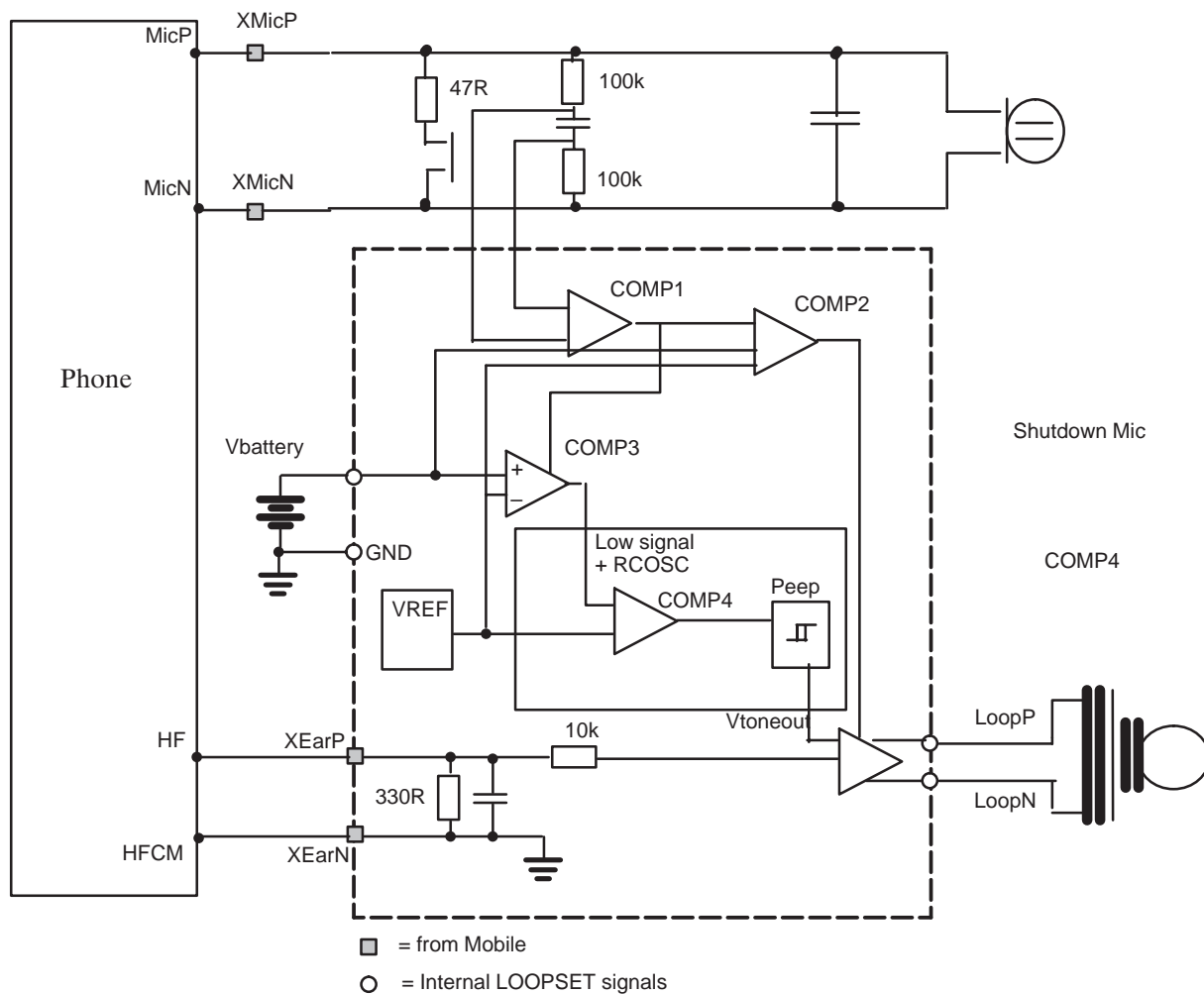

## Plug and X100 connector signals

Plug / Jack	Pin in x100	Name	Function	Min	Typ	Max	Unit	Description
1	1	<b>XMicP</b>	Loopset microphone input (from accessory to phone)		1.6		kΩ	Loopset source AC impedance ref 1kHz
						400	μA	Bias current
						200	mV-p-p	Maximum signal level
		Loopset detection (from accessory to phone)	2,4		2,8 6	V	No Loopset (ref. <b>XMicN</b> ).	
			1.1		2,2 3	V	Loopset connected (ref. <b>XMicN</b> ). Mic bias ON	
		<b>Ead / hookint mbus</b>	Ext accessory detection Bias OFF	0	0.3 0.1	1.0 0.3 5	V	Loopset connected (ref. GND).
<b>Ead / Hookint mbus</b>	Button closed DCT3.n Mic bias ON DCT4	0.7 0 1.0		0.8 0 1.2	V	Loopset connected (ref. GND).		
3	2	<b>XMicN</b>	Microphone + signal		10		nF	Series output capacitance
2	3	<b>XEarN</b>	EAR –Signal (from phone to accessory)		47		Ω	Output AC impedance ref 1kHz
					10		nF	Series output capacitance
				150	300	450	Ω	Load AC impedance ref 1kHz
					2.0		Vpp	Max. input level. No load
4	4	<b>XEarP</b>	Ear + signals					

## Exploded View of LPS-3

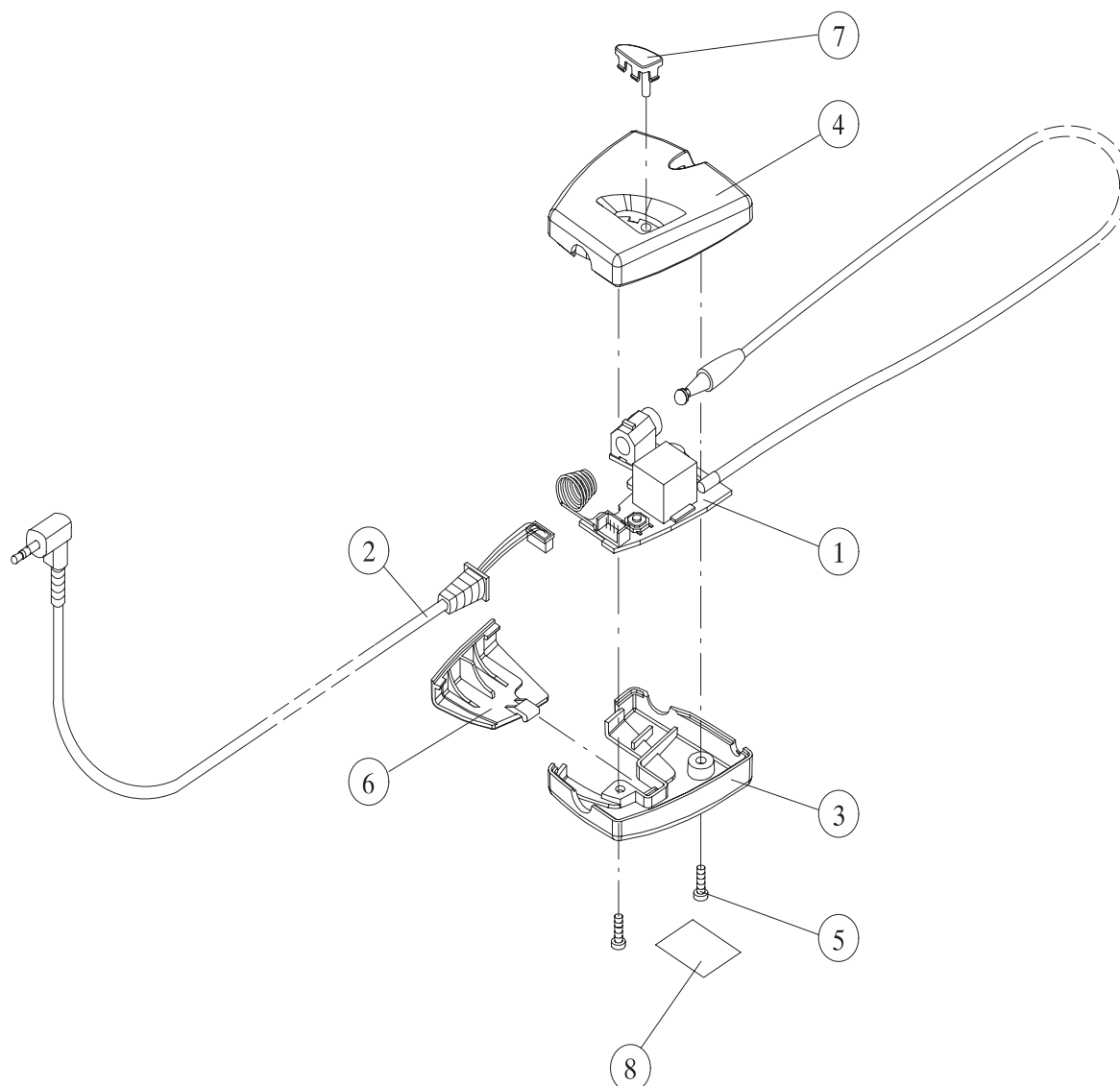

### Assembly parts of LPS-3

ITEM	Q'TY	CODE	DESCRIPTION	VALUE, TYPE
1		0201489	Module	lps-3
2		9780260	Loop set Cable LPS-3	DMJ00180
3		9451692	B-cover	DMD05510
4		9451691	A-cover	DMD05509
5	2	6290021	PT-screw	1,8x8 feznTX6
6		9451693	Battery lid	DMD05507
7		9451694	Button	DMD05511
8		9380750	Type label	

Note: The torque of the screws is 0.35 Nm.

## Parts List of LPS-3

(Version 6.1)			Code: 0201179	
ITEM	CODE	DESCRIPTION	VALUE	TYPE
R001	1430784	Chip resistor	15 k	5 % 0.063 W 0402
R003	1430796	Chip resistor	47 k	5 % 0.063 W 0402
R004	1430778	Chip resistor	10 k	5 % 0.063 W 0402
R005	1430804	Chip resistor	100 k	5 % 0.063 W 0402
R006	1430792	Chip resistor	33 k	5 % 0.063 W 0402
R018	1430778	Chip resistor	10 k	5 % 0.063 W 0402
R020	1430796	Chip resistor	47 k	5 % 0.063 W 0402
R021	1430804	Chip resistor	100 k	5 % 0.063 W 0402
R024	1430792	Chip resistor	33 k	5 % 0.063 W 0402
R025	1430796	Chip resistor	47 k	5 % 0.063 W 0402
R026	1430122	Chip resistor	4.7 M	5 % 0.063 W 0603
R027	1430790	Chip resistor	27 k	5 % 0.063 W 0402
R028	1430804	Chip resistor	100 k	5 % 0.063 W 0402
R031	1430778	Chip resistor	10 k	5 % 0.063 W 0402
R032	1430804	Chip resistor	100 k	5 % 0.063 W 0402
R033	1430780	Chip resistor	12 k	5 % 0.063 W 0402
R034	1430784	Chip resistor	15 k	5 % 0.063 W 0402
R035	1430788	Chip resistor	22 k	5 % 0.063 W 0402
R036	1430778	Chip resistor	10 k	5 % 0.063 W 0402
R037	1430778	Chip resistor	10 k	5 % 0.063 W 0402
R039	1430804	Chip resistor	100 k	5 % 0.063 W 0402
R041	1430804	Chip resistor	100 k	5 % 0.063 W 0402
R042	1430812	Chip resistor	220 k	5 % 0.063 W 0402
R043	1430804	Chip resistor	100 k	5 % 0.063 W 0402
R044	1430778	Chip resistor	10 k	5 % 0.063 W 0402
R046	1430762	Chip resistor	2.2 k	5 % 0.063 W 0402
R047	1430804	Chip resistor	100 k	5 % 0.063 W 0402
R048	1430812	Chip resistor	220 k	5 % 0.063 W 0402
C002	2610003	Tantalum cap. 3.2x1.6x1.6	10 u	20 % 10 V
C005	2610003	Tantalum cap. 3.2x1.6x1.6	10 u	20 % 10 V
C006	2320779	Ceramic cap.	100 n	10 % 16 V 0603
C008	2610101	Tantalum cap.	22 u	20 % 3.5x2.8x1.9
C009	2320592	Ceramic cap.	2.2 n	5 % 50 V 0402
C010	2320546	Ceramic cap.	27 p	5 % 50 V 0402
C015	2320580	Ceramic cap.	680 p	5 % 50 V 0402
C017	2320580	Ceramic cap.	680 p	5 % 50 V 0402
C018	2320469	Ceramic cap.		Y5 V 0603
C021	2320779	Ceramic cap.	100 n	10 % 16 V 0603
C022	2320592	Ceramic cap.	2.2 n	5 % 50 V 0402
C023	2320580	Ceramic cap.	680 p	5 % 50 V 0402
C024	2320107	Ceramic cap.	10 n	5 % 50 V 0603

C025	2320546	Ceramic cap.	27 p	5 % 50 V 0402
C026	2320779	Ceramic cap.	100 n	10 % 16 V 0603
C027	2320779	Ceramic cap.	100 n	10 % 16 V 0603
C029	2320107	Ceramic cap.	10 n	5 % 50 V 0603
C030	2320107	Ceramic cap.	10 n	5 % 50 V 0603
C031	2320779	Ceramic cap.	100 n	10 % 16 V 0603
C033	2320546	Ceramic cap.	27 p	5 % 50 V 0402
C034	2320779	Ceramic cap.	100 n	10 % 16 V 0603
C035	2320592	Ceramic cap.	2.2 n	5 % 50 V 0402
C038	2320564	Ceramic cap.	150 p	5 % 50 V 0402
C039	2320469	Ceramic cap.		Y5 V 0603
C040	2320469	Ceramic cap.		Y5 V 0603
C041	2320779	Ceramic cap.	100 n	10 % 16 V 0603
C053	2320584	Ceramic cap.	1.0 n	5 % 50 V 0402
C221	2320779	Ceramic cap.	100 n	10 % 16 V 0603
C261	2320546	Ceramic cap.	27 p	5 % 50 V 0402
C262	2320546	Ceramic cap.	27 p	5 % 50 V 0402
B001	5140117	Cond.mic 45+−3DB	33PF 2K	D5.8/9.D5.8/9.0
Z001	3640035	Filt z>450r/100m 0r7max 0.2a		0603
Z002	3640035	Filt z>450r/100m 0r7max 0.2a		0603
T001	3640073	Af−transformer for manual p&p smd		SMD
V400	4219922	Transistor x 2		UM6
V401	4219922	Transistor x 2		UM6
V405	4219904	Transistor x 2	UMX1	npn 40 V SOT363
V406	4219908	Transistor x 2		SOT363
N003	4340379	IC, 2xop amp 2.7/3v sso	LMC6572BIMM	SSOP8
N402	4340331	IC, Power amp. LM4862	P W	SO8S
X100	5409067	SM, pin header 1x04 p1.25 1a s		STR.
X200	5400125	SM, pcb conn 4mm f		90deg
	6400039	Battery spring	dmd03655	lps−1
	9854251	PCB LPS1 28.2X33.1X1.0 M4 24/PA		